

Triple HD-video AFE digitizer - 10bits/170Mhz - 8bits/205Mhz

Overview:

This macro is a triple-channel, 8/10-bits video analog front end (AFE) that incorporates all of the functions required to digitize YpbPr/YUV (component) video signals and RGB (red, green, blue) graphic signals from DVD players, VCRs, set-top boxes and personal computers.

It contains all the video and timing pre-processing circuits, offset control, gain control, bottom and mid-scale clamping, SOG slicer, VSYNC/HSYNC extractor, 32 phases clock shift control, internal or external clamp and coast signals generation, as well as an analog pixel clock PLL with optimized long term jitter <500ps.

This IP is fully programmable through 2 wires I2C interface.

Features:

- Triple channel video 10bits digitizer 170Mhz
- 0.5 to 1V analog input range
- 3.3V/1.8V $\pm 10\%$ supply voltage, -40/+125°C
- 1P6M layout structure based on 0.18um 1P6M 3.3V/1.8V generic logic process.
- Analog PLL with 32 phases shift control
- Adjustable bandwidth : 75, 150, 300, 500Mhz
- Programmable Clamp and Coast generation
- Area: [contact us]
- Power consumption [contact us]
- Power down leakage current <1uA
- Fully programmable through I2C interface
- Antenna diodes on each digital input.
- uses MIM capacitor

Block Diagram:

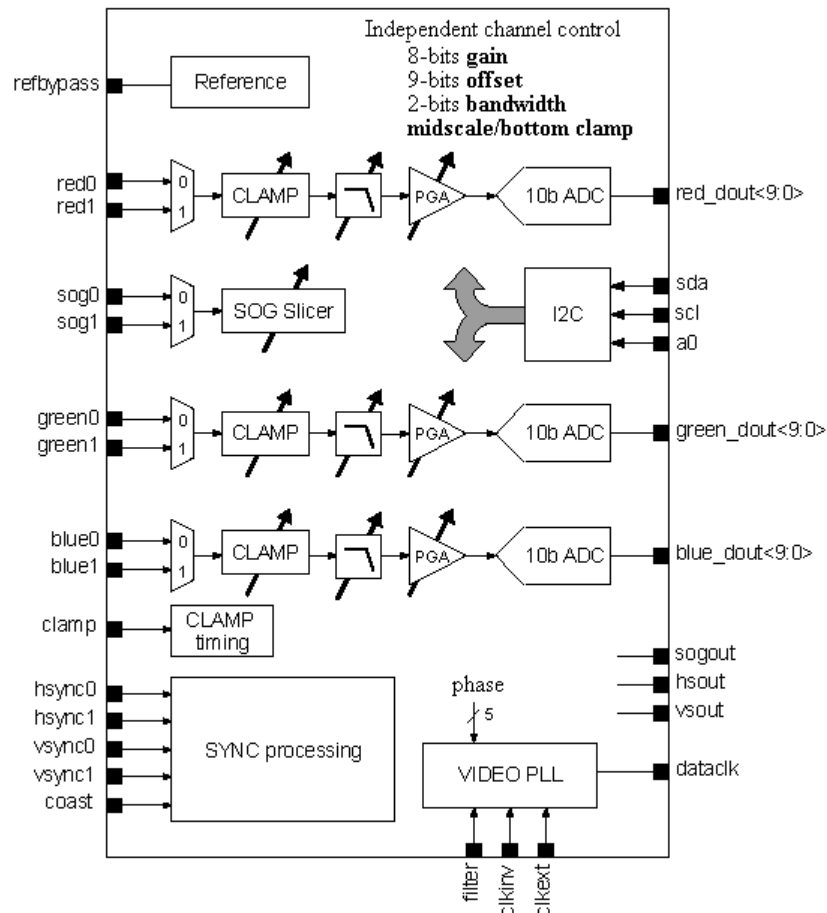

Deliverables:

V-Trans provides 2 separate kits depending on licensing agreement.
In most cases, the physical is merged on foundry site.

Design Kit

Design kit includes :

- LEF view and abstract gdsII
- Verilog HDL behavioral model
- Liberty (.lib) timing constraints for typical, worse and best corner case
- Full Datasheet /Application Note with integration guidelines document
- Silicon characterization report when available

Tapeout Kit

Tapeout kit includes the design kit plus physical view:

- gdsII
- LVS netlist and report
- DRC/ERC/ESD/ANT report

Portfolio and Design Services:

V-Trans Microelectronics has been combining all the best practices and methodologies in analog and mixed-signal high speed interfaces design to answer the demanding market of high performance analog IPs using cheaper technologies such as 0.18um.

Our Portfolio covers a wide range of applications and can be customized on demand to answer exactly your specific needs.

Custom layout and back-end services are also available if you have a tight project schedule.

Our experience includes high integration circuit such as network SOC, CPU and FPGA which allow us to provide a full solution for even more complex chip.

Please contact us to tell us how we could help you or for any analog IP information.

- High speed interfaces (LVDS serdes, Display Interfaces, DDRII, DDR3, PCI-X, HDMI rev1.1)
- Converters (video ADC 10b 170Mhz, Triple video DAC)
- Timing circuits (Audio PLL, Video PLL, DDR memory PLL, custom PLL.)
- Low noise Crystal Oscillators
- Power management (LDO regulators, Power On Reset..)
- Video and WIMAX Analog Front end

V-TRANS Microelectronics – Shanghai Office
Tel: (+86)-021-54234123
v-trans@v-trans.com